



东莞市滑翔世界电子科技有限公司

Dongguan City Gliding World Electronic Technology Co., Ltd

Tel: +86-15017035700

http://www.gdwsevo.com

E-mail: duncan@gdwsevo.com

G92规格书 General Specs

Operation Voltage Range 电压范围	4.8V up to 8.4 V
Operation Temperature Range 适应温度	-20C° up to +60C°
Working frequency 工作频率	1520us/333Hz

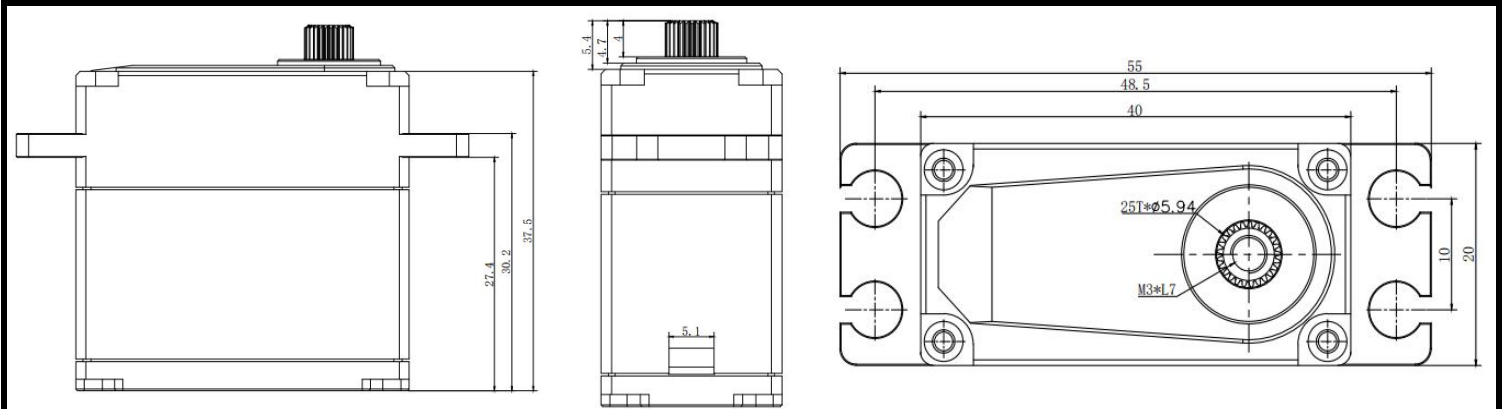

测试参数 Bench tests reported values

电压 Test Voltage	6.0V	7.4V	8.4V
速度 Speed	0.125sec/60°	0.1sec/60°	0.09sec/60°
扭力 Torque	31Kg. cm	38Kg. cm	43Kg. cm
Fast continuous operating current 快速持续工作电流	800mA	1000mA	1200mA
堵转电流 Stall current	4600mA	5500mA	6000mA
死区 Dead Band Width	2μ		

一般数据 General Data

电机型号 Motor Type	无刷电机 Brushless motor 17*18mm
电位器类型 Potentiometer Type	日本noble 220° Japan noble 220°
芯片类型 Chip type	数字 Digital
重量 Weight	77±1g
齿轮组材质 Gear Material	钢 steel
输出齿数 Horn Gear Spline	25T φ5.9mm
线长 Wire length	330 ±5mm
线径 Wire Diameter	0.3mm ²
线芯数量 Number of wire cores	60