



东莞市滑翔世界电子科技有限公司

Dongguan City Gliding World Electronic Technology Co., Ltd

Tel: +86-15017035700 http://www.gdwservo.com E-mail: duncan@gdwservo.com

BLS992HV规格书 General Specs

| | |
|---|-------------------|
| Operation Voltage Range 电压范围 | 4.8V up to 8.4 V |
| Operation Temperature Range 适应温度 | -20C° up to +60C° |
| Working frequency 工作频率 | 1520us/333Hz |

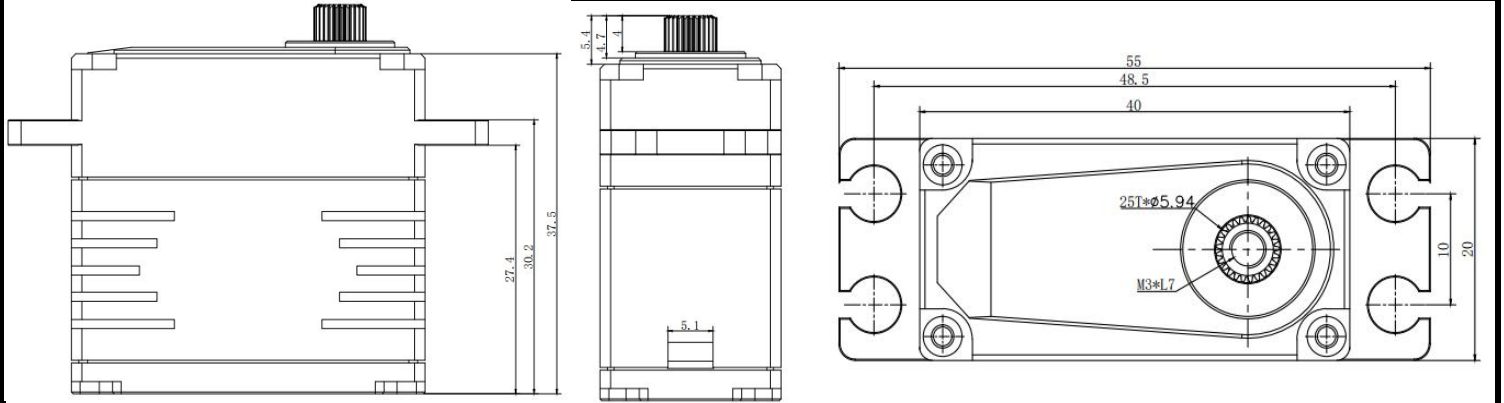

测试参数 Bench tests reported values

| 电压 Test Voltage | 6.0V | 7.4V | 8.4V |
|---|-------------|--------------|--------------|
| 速度 Speed | 0.08sec/60° | 0.065sec/60° | 0.055sec/60° |
| 扭力 Torque | 20Kg. cm | 25Kg. cm | 28Kg. cm |
| Fast continuous operating current 快速持续工作电流 | 900mA | 1000mA | 1100mA |
| 堵转电流 Stall current | 4600mA | 5400mA | 6000mA |
| 死区 Dead Band Width | 2μ | | |

一般数据 General Data

| | |
|---------------------------|-------------------------------|
| 电机型号 Motor Type | 无刷电机 Brushless motor 17*18mm |
| 电位器类型 Potentiometer Type | 日本noble 220° Japan noble 220° |
| 芯片类型 Chip type | 数字 Digital |
| 重量 Weight | 77±1g |
| 齿轮组材质 Gear Material | 钢 steel |
| 输出齿数 Horn Gear Spline | 25T φ5.9mm |
| 线长 Wire length | 330 ±5mm |
| 线径 Wire Diameter | 0.3mm ² |
| 线芯数量 Number of wire cores | 60 |