



东莞市滑翔世界电子科技有限公司

Dongguan City Gliding World Electronic Technology Co., Ltd

G50HV规格书 General Specs

Operation Voltage Range 电压范围	4.8V up to 8.4 V
Operation Temperature Range 适应温度	-20C° up to +60C°
Working frequency 工作频率	1520us/333Hz

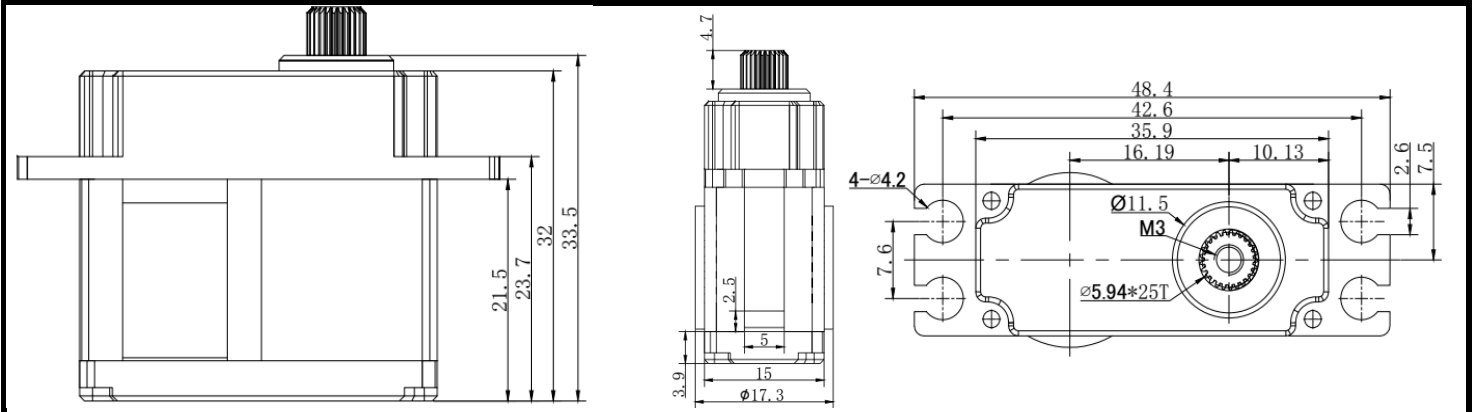

测试参数 Bench tests reported values

电压 Test Voltage	6.0V	7.4V	8.4V
速度 Speed	0.09sec/60°	0.08sec/60°	0.07sec/60°
扭力 Torque	9.0Kg. cm	10Kg. cm	11Kg. cm
Fast continuous operating current 快速持续工作电流	700mA	900mA	1100
堵转电流 Stall current	2500mA	3000mA	3500mA
死区 Dead Band Width	2μ		

一般数据 General Data

电机型号 Motor Type	无刷电机 Brushless motor 17*15mm
电位器类型 Potentiometer Type	日本noble 220° Japan noble 220°
芯片类型 Chip type	数字 Digital
重量 Weight	47±1g
齿轮组材质 Gear Material	镀钛处理 The surface treatment of titanium
输出齿数 Horn Gear Spline	25T φ 5.9mm
线长 Wire length	220 ±0.5mm
线径 Wire Diameter	0.15mm ²
线芯数量 Number of wire cores	30